

PRODUCT FEATURES

In industry, particularly in the food industry, it's necessary to comply with strict hygiene regulations. Especially where heavy air humidity is prevalent, there's a need for natural ventilation through a vent. Therefore it's necessary to aerate the spaces regularly, without the intrusion of insects and small birds. The same can be applied to logistics centers and supermarkets. To avoid these situations, our products offer two solutions: anti-bird mesh and insect mesh.

This optional, built with drawers, can be accessed from the roof for cleaning purposes, even during operation. The system of drawers, accompanied by casters, and fastening clamps, ensure correct sealing and extremely fast maintenance.

It is versatile because it can be easily adapted to products such as VENTRA, DELTA, MEGADELTA, and KALON.

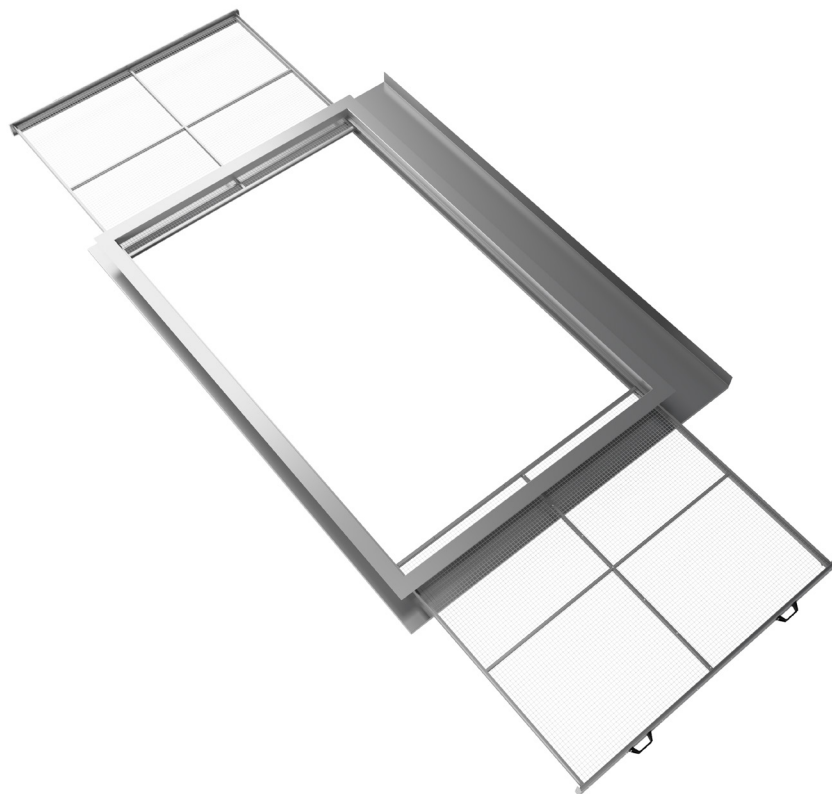

insect drawer

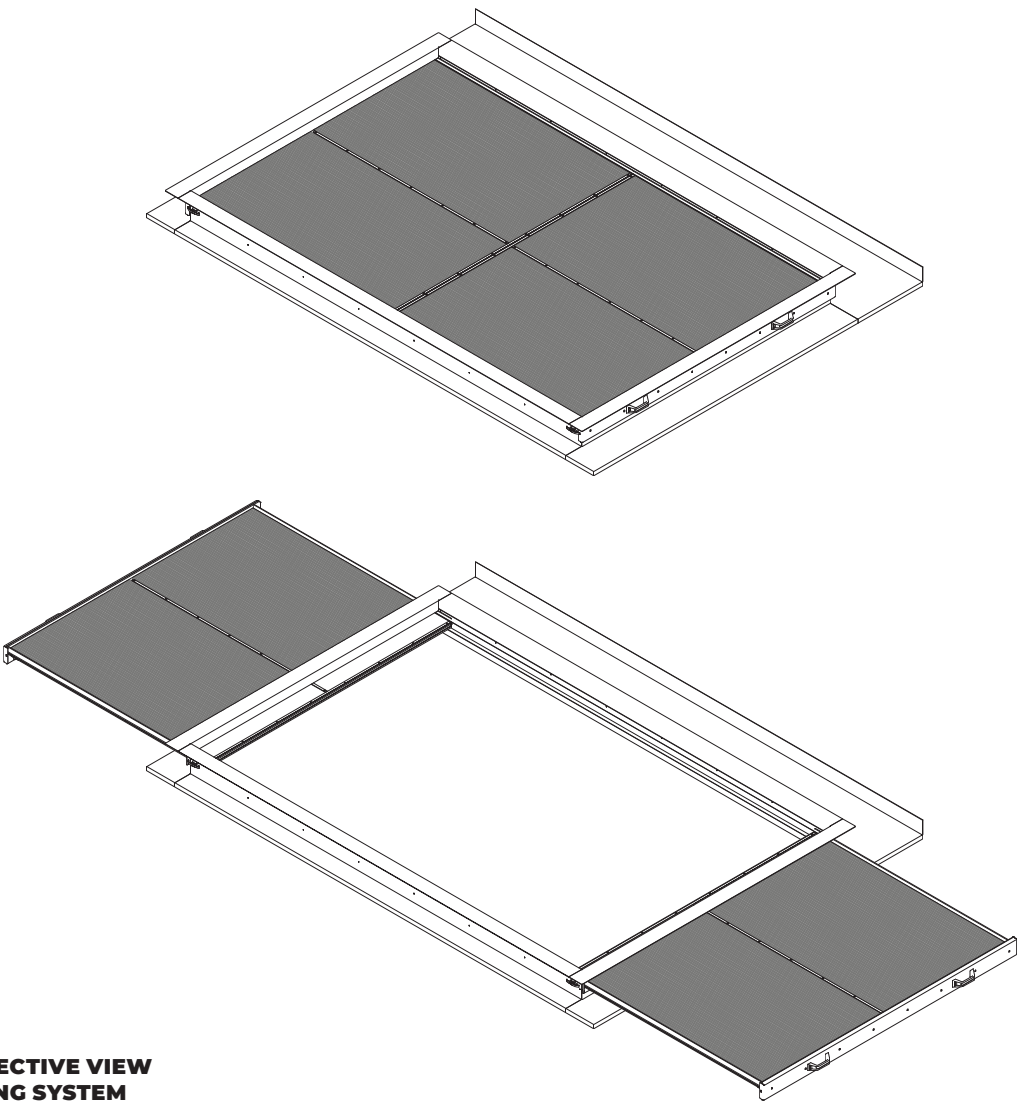
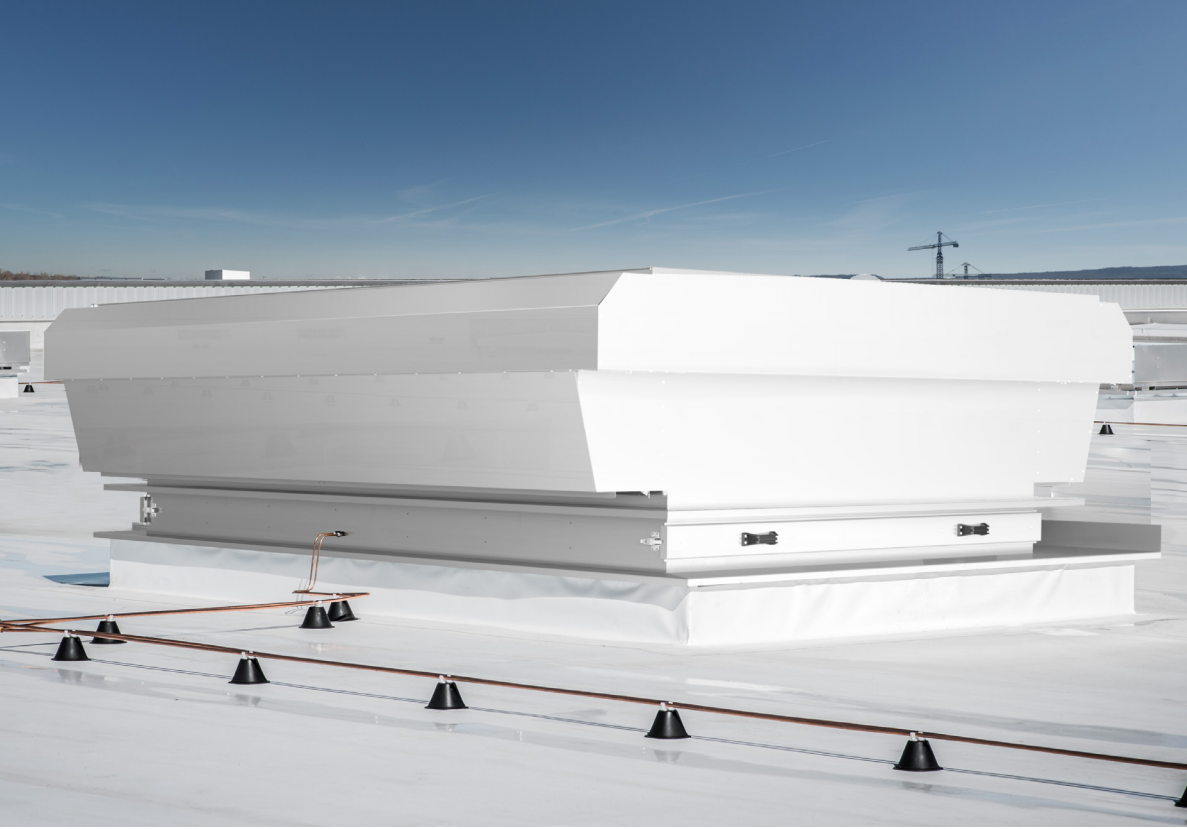

**PERSPECTIVE VIEW
OPENING SYSTEM**

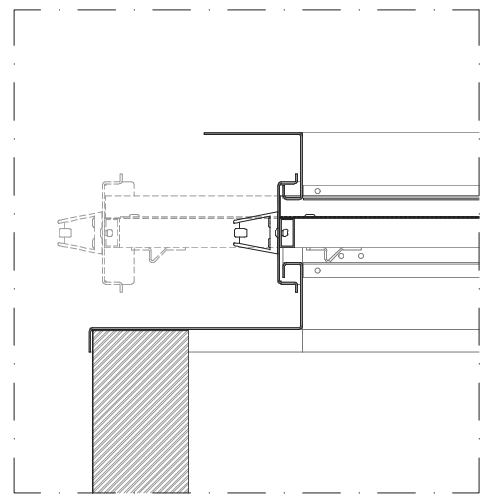
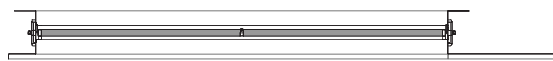
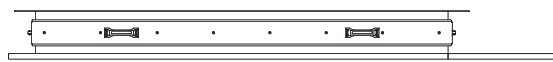
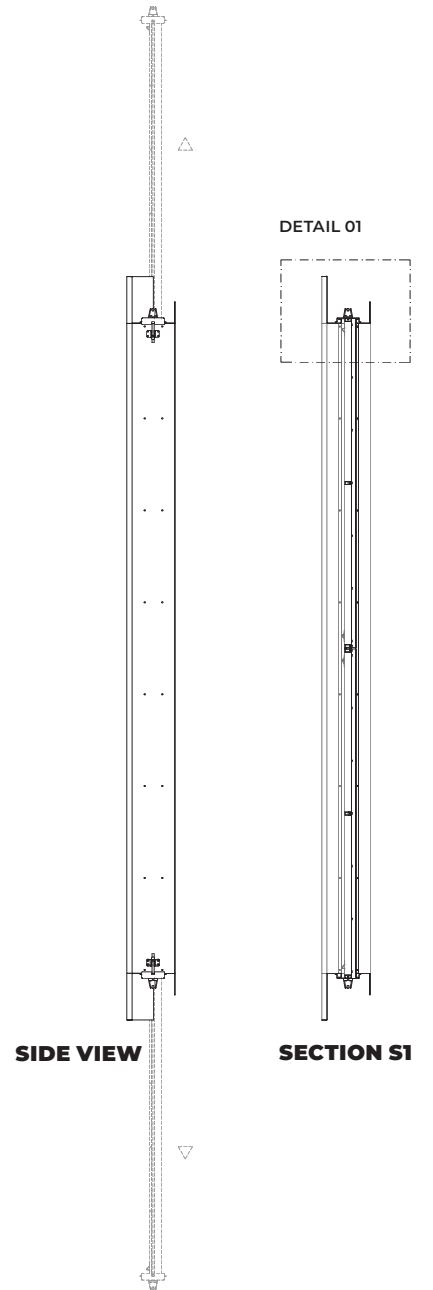
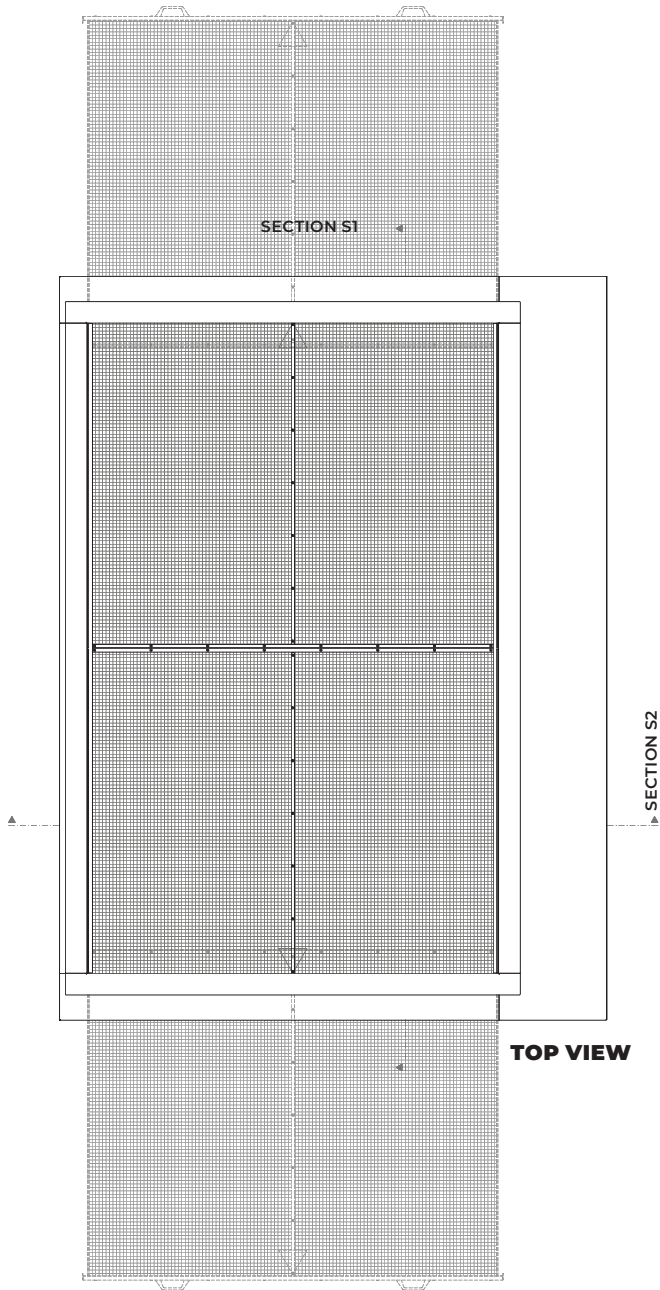

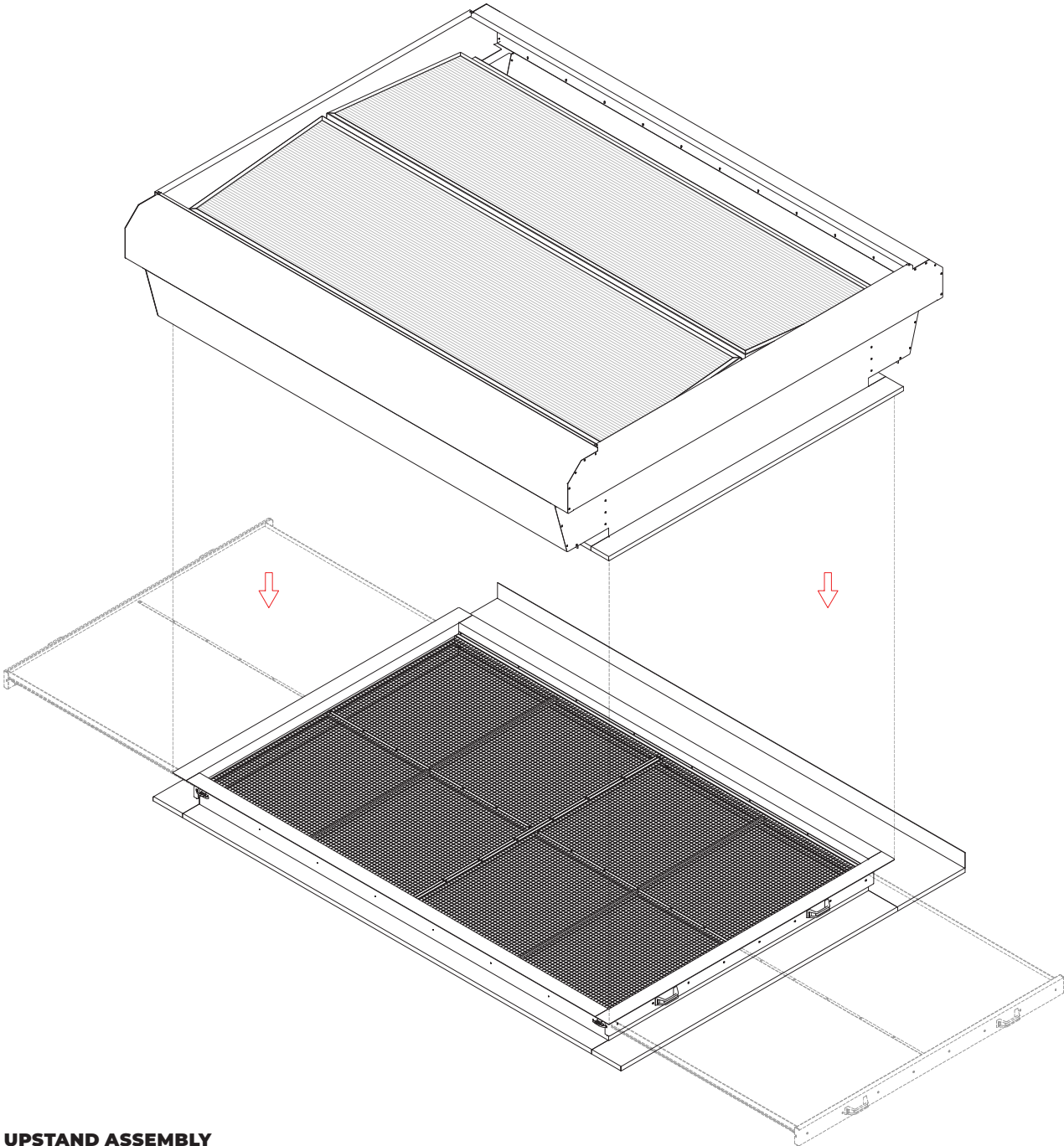

UPSTAND ASSEMBLY

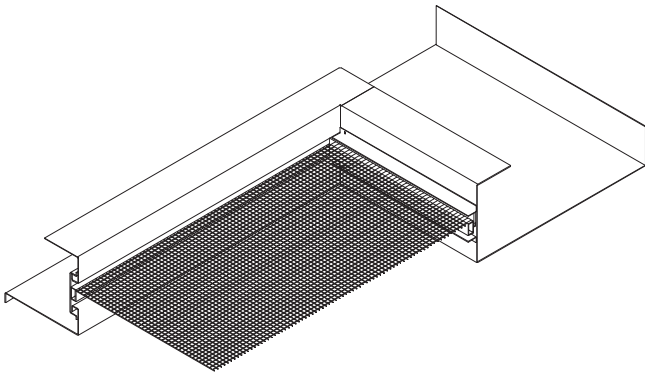

INSECT MESH

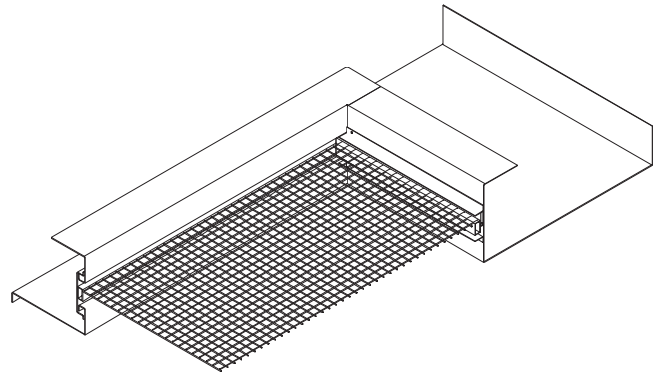

BIRD MESH